

aPower S

The aPower S is a battery storage device with integrated inverters to support a direct connection to solar (PV) panels. The front wiring design makes installation easier and more efficient.

The aPower S also supports parallel connection with FranklinWH aPower 2 batteries to expand power and capacity at the same time. It can be flexibly deployed according to customer requirements. Excellent load adaptability provides the best backup experience to users.

aPower S has a 15 kWh capacity, which can provide a whole home backup with a single battery. It provides an ultra-large throughput of 60 MWh during the 15-year warranty period, helping users to easily achieve reliable energy independence and freedom.

- ✓ Four built-in MPPTs
- ✓ 15 kWh per unit, up to 225 kWh (15 units) per aGate
- ✓ 15 A per MPPT
- ✓ 10 kW continuous / 15 kW peak for 10s
- ✓ RTE 90.5%
- ✓ Normal operations down to -4° F (-20° C)
- ✓ Safe LFP chemistry
- ✓ A single aPower S is capable of starting a 5-Ton AC
- ✓ IP67 weather protection



PERFORMANCE SPECIFICATIONS

| | | | | | |
|--|--|---------|---------|---------|----------|
| SKU | APRS-10K15V1-US | | | | |
| Model Number | aPower S-10 | | | | |
| Battery Chemistry | Lithium Iron Phosphate (LFP) | | | | |
| Usable System Energy | 15 kWh per unit, up to 15 units per aGate ¹ | | | | |
| Aggregate Throughput | 60 MWh | | | | |
| Real Power (charge) | 8 kW continuous | | | | |
| Real Power (Discharge) | 10 kW continuous, 15 kW peak for 10 seconds | | | | |
| Nominal Output Power (AC) | 2.5 kW | 5 kW | 6.7 kW | 8.4 kW | 10 kW |
| Maximum Apparent Power | 2.9 kVA | 5.8 kVA | 7.7 kVA | 9.6 kVA | 11.5 kVA |
| Maximum Continuous Current | 12 A | 24 A | 32 A | 40 A | 48 A |
| Nominal AC Voltage | 120 / 240 V, 120 / 208 V (single phase), 60 Hz | | | | |
| Grid Voltage Range | 183 V-228 VAC; 211-264 VAC | | | | |
| Phase | 2 W+N+PE | | | | |
| Round Trip Efficiency | 90.5% ² | | | | |
| Maximum Short-Circuit Current Rating | 10 kA | | | | |
| Load Start Capability | Up to a 5-ton air conditioner ³ | | | | |
| Work Modes | Self-Consumption Time of Use Emergency Backup | | | | |
| Noise Emission | 30 dB(A) Typical / 45 dB(A) Maximum | | | | |
| Flood Resistance | Up to 29" from the aPower S base | | | | |
| User Interface | FranklinWH App | | | | |
| Warranty | 15 years | | | | |
| Maximum Solar STC Input | 20 kW | | | | |
| Withstand Voltage | 600 Vdc | | | | |
| PV DC Input Voltage Range | 60 - 550 V DC | | | | |
| PV DC MPPT Voltage Range | 90 - 480 V DC | | | | |
| MPPTs | 4 | | | | |
| Maximum Current per MPPT (Imp) | 15 A | | | | |
| Maximum Short Circuit Current per MPPT (Isc) | 20 A | | | | |

1. For 120/208 V applications, max. 2 aPowers per aGate can be connected in parallel. Please contact FranklinWH if you have large capacity requirements.
 2. Solar to Battery to Home/Grid Efficiency. Values provided for 25°C (77°F), at the beginning of life. Charging (PV to battery) @4.8kW, Discharging (battery to AC) @3.5kW.
 3. Load start capability may vary.

COMPLIANCE INFORMATION

| | |
|----------------|---|
| Certifications | UL9540; UL9540A; UL1973; UL1741; UL1741 SB; UL1741 PCS; UL1699B; UL1998; UN38.3; IEEE 1547; IEEE 1547.1; CSA 22.2 No.107.1; |
| Seismic | AC 156, OSHPD, IEEE 693-2005 (high) |
| Environmental | California Proposition 65 |
| Emissions | FCC Part 15 Class B, ICES 003 |

MECHANICAL SPECIFICATIONS

| | |
|-----------------------------|--|
| Dimensions (H x W x D) | 45.2 in x 29.5 in x 11.8 in (1149 mm x 750 mm x 300 mm) |
| Weight of aPower S Complete | 381 lbs (173 kg) |
| Mounting | Wall or floor mount |
| Cooling | Natural air-cooled design |

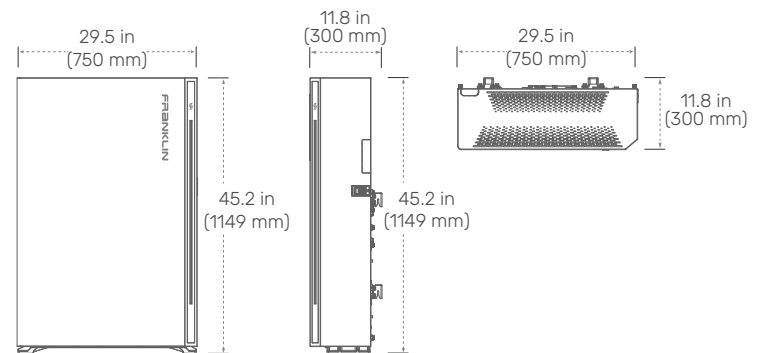

ENVIRONMENTAL SPECIFICATIONS

| | |
|-------------------------|---|
| Enclosure Type | Type 3R |
| Ingress Protection | IP67 (Battery Pack & Inverter) IP55 (Wiring) |
| Operating Temperature | -4° F to 122° F (-20° C to 50° C) Operates up to 131°F (55°C) at 5 kW derated output |
| Operating Humidity (RH) | Up to 100% RH, condensing |
| Altitude | Maximum 9,843 ft (3,000 m) |
| Environment | Indoor and outdoor rated |